



Electromechanical High Precision Time Relay

MZ 54 for single voltage

Function: ON-delay (AV)

1 setting range, divided into 6 time ranges

**Contact equipment: 4 timed changeover or
3 timed and 1 instantaneous changeover or
2 timed and 2 instantaneous changeover or
1 timed and 3 instantaneous changeover**

MZ 54

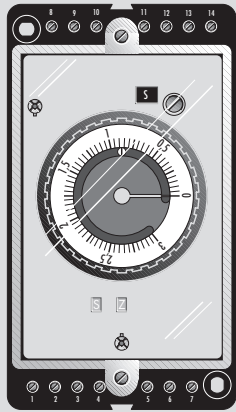

General

AV (see page M 5/3).

The electromechanical high precision time relay is equipped with a synchronous motor and a solenoid clutch.

The setting of the time ranges is done on the timer's front by means of a selector switch. Infinitely variable time setting within a range is carried out with the aid of a transparent rotary knob.

The time-remaining indicator moves during operation from zero in the direction of the set time and jumps back to zero after the output contacts changed over. The device is equipped with a contact position indicator on the front. Thus depending upon the relay function, the position of the instantaneous or timed contacts is indicated by the symbols S (instantaneous) and Z (timed).

Function

Upon energization of motor and solenoid, the swing-out gear train axle is coupled to the timing mechanism and the instantaneous contact (symbol S in the contact position indicator) is actuated. The timing operation starts. When the preset time has elapsed, the timed contact (symbol Z in the contact position indicator) is actuated and the motor is switched off.

Upon de-energization, the clutch, timing mechanism and all contacts go into their off-position (no symbols appear in the contact position indicator). If a voltage interruption occurs during the timing period, the clutch, the instantaneous contact and timing mechanism go back into their off-position.

In the case of the electromechanical high precision time relay MZ 54 it is possible to select the number of timed and instantaneous contacts with the aid of an inboard contact selector lever:

Changeover	Position of the contact selector lever			
	D	C	B	A
13/14-12	Z	S	S	S
10/11-9	Z	Z	S	S
7/ 8-6	Z	Z	Z	S
4/ 5-3	Z	Z	Z	Z

Z = timed contacts, that switch after timing operation
S = instantaneous contacts, that change over upon energization

Function Diagram

FD 0040

MZ 54

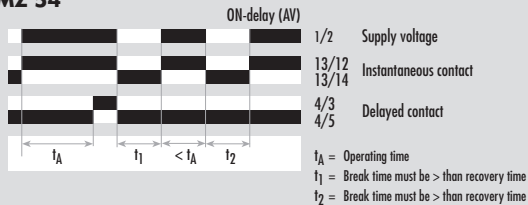

Connection Diagram

KS 5035/3

MZ 54

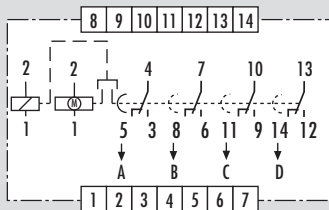

Dimensions

M 2-3

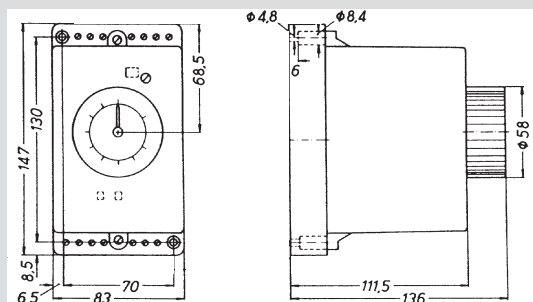

Note

- ▶ The relay has an inboard frequency switch that can be set to 50 or 60 Hz, depending on the connected external supply. The factory presetting is 50 Hz.
- ▶ Maximum accuracy (repeatability) is achieved by selecting the shortest possible timing range.
- ▶ No maintenance is necessary.



Electromechanical High Precision Time Relays

Product Description

The electromechanical high precision time relay MZ 54 is available with one setting range, divided into 6 time ranges.

Setting Range	Time Range
0,15 s to 30 h divided into :	0,15 to 3 s
	1,5 to 30 s
	0,15 to 3 min
	1,5 to 30 min
	0,15 to 3 h
	1,5 to 30 h
or	
0,3 s to 60 h divided into :	0,3 to 6 s
	3 to 60 s
	0,3 to 6 min
	3 to 60 min
	0,3 to 6 h
	3 to 60 h

Accessories

Lockable cover V 3

Price code for accessories (see page M 5/19).

Type	Standard voltage	Price Code
MZ 54 30 h	24 V AC	M 5/5.1
MZ 54 60 h	110 to 115 V AC	
	230 V AC	
	50 and 60 Hz	



Electromechanical High Precision Time Relays

TECHNICAL DATA

FUNCTION according to DIN VDE 0435 Part 1 110:04.89

Point 3.13

Function display
Function diagram

POWER SUPPLY

Rated voltage U_N V AC

Rated consumption: motor at 50 Hz and U_N (AC) VA
 Rated consumption: motor at 50 Hz and U_N (AC) W
 Rated consumption: coil at 50 Hz and U_N (AC) VA
 Rated consumption: coil at 50 Hz and U_N (AC) W
 Rated frequency Hz
 Operating voltage range

TIME CIRCUIT

Time setting/Number of time ranges
2 setting ranges available

Recovery time ms
 Minimum switch-ON time ms
 Release value % U_N
 Permissible parallel load yes
 Internal rectifier yes
 Average of the error related to the full-scale value -
 Dispersion
 Setting range 0,15 to 3 s s
 Setting range 0,3 to 6 s s
 Setting range 0,6 to 12 s s
 Setting range 1,5 to 30 s s
 Setting range 3 to 60 s s
 Maximum operating time ≥ 3 min %

OUTPUT CIRCUIT

Contact equipment

Contact material
 Available modifications
 Switching voltage U_n V AC/DC
 Maximum continuous current I_n A
 Application category according to EN 60947-5-1:1991

Permissible switching frequency switching cycles/h
 Mechanical service life switching cycles
 Response time ms
 Release time ms

GENERAL DATA

Creepage and clearance distances between circuits according to DIN VDE 0110-1:04.97: rated surge voltage kV
 Over voltage category III
 Contamination level 3 outside, 2 inside
 Design voltage V AC
 Test voltage U_{eff} 50 Hz acc. to DIN VDE 0110-1, Table A.1 kV
 Protection class housing/terminals acc. to DIN VDE 0470 Sec. 1:11.92
 Radiated noise
 Noise immunity

Ambient temperature, working range °C
 Dimensions
 Connection diagram
 Weight kg
 Accessories

Approvals

GENERAL TECHNICAL SPECIFICATIONS

MZ 54

Electromechanical high precision time relay for single voltage
 ON-delay time relay
 Operating time indicator
 FD 0040

24	110-115	230
----	---------	-----

ca. 0,9
ca. 1,0
ca. 14,2 pick-up/ca. 8,8 hold
ca. 11 pick-up/ca. 3,4 hold
50 and 60 switchable on the device
0,8 to 1,1 x U_N

analog/6
 1. setting range 0,15 s to 30 h
 divided into: s. item description
 2. setting range 0,3 s to 60 h
 divided into: s. item description

≤ 250	
-	
≥ 15	
yes	
yes	
-	
Standard duty	Rapid start
$\pm 0,04$	$\pm 0,01$
$\pm 0,055$	$\pm 0,025$
$\pm 0,08$	$\pm 0,05$
$\pm 0,15$	$\pm 0,12$
$\pm 0,27$	$\pm 0,24$
$\pm 0,4$ related to the full-scale value	

maximum of 4 timed changeover, timed and instant. contacts selectable with a contact selector lever
 Ag Cd O
 Ag Pd 70/30*
 400/400
 5
 AC-15 U_e 230 V AC, I_e 2 A
 DC-13 U_e 24 V DC, I_e 2 A
 3000
 30 x 10⁶
 ≤ 20
 ≤ 70

5
 III
 3 outside, 2 inside
 400
 2,68
 IP 30/IP 20
 EN 50081-1:03.93, -2:03.94
 EN 50082-2:1995

- 10 to + 55
 M 2-3
 KS 5035/3
 1,2
 lockable cover V 3

page i.4

page i.5

*) Price: upon request