



Two-Hand Relay

SNZ 5052K

PI 0097-0103 E



EN 60204-1	For Stop Category	0
EN 954-1	Safety Category	4
EN 574-1	Requirements	Type III C

- Safety switching device for two-hand controls acc. to EN 574-1: type IIIC, category 4 acc. to EN 954-1
- Stop category 0
- Safe isolation between supply, control and enable circuits
- Supply voltage up to 230 V AC, control voltage 24 V DC
- Two-channel control, 1 N/O and 1 N/C per channel
- Feedback circuit, startup block
- Synchronous time monitoring ≤ 0.5 s
- 2 enable contacts
- Bridge-fault detection
- Automatic start during operation
- Air and creepage paths ≥ 5.5 mm
- LED status indicator

Applications

Two-hand controls and safety door monitoring, especially at

- Presses
- Packaging equipment
- Machine tools
with supply voltages from 24 V DC to 230 V AC

Device Description

The SNZ 5052K is enclosed in a 22.5 mm wide case for 35 mm DIN mounting rails acc. to EN 50022. The units are connected by means of screw terminals.

Principle of Operation

The SNZ 5052K is used to monitor two-hand momentary-contact switches with a two-channel design (1 N/C and 1 N/O). When supply voltage is applied, the "SUPPLY" LED lights up indicating that the device is ready for operation. In order to enable both two-hand switches by simultaneous activation, both two-hand switches must be idle and the feedback circuit must be closed. Upon releasing one or both two-hand switches enabling is cancelled. The relay can be re-enabled only after both two-hand switches have been released and are activated again within the synchronous time. The startup block prevents a release upon voltage recovery and operation of the two-hand switches.

Notes

Expansion units, such as SNE 4004K, SNO 3004, or external contactors with positively driven contacts may be used to multiply the enabling current paths. The feedback circuit switching architecture depends on the required safety level.

Device Options

Rated voltage	
DC 24 V	AC 115 - 120 V
AC 24 V	AC 230 V

Ordering Example

SNZ 5052K 24 V DC

Function Diagram

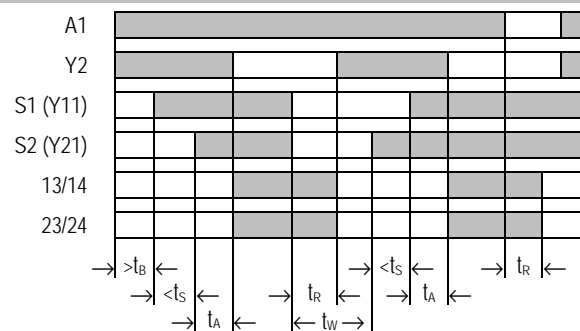

For time data, see technical specifications

Connection Diagram

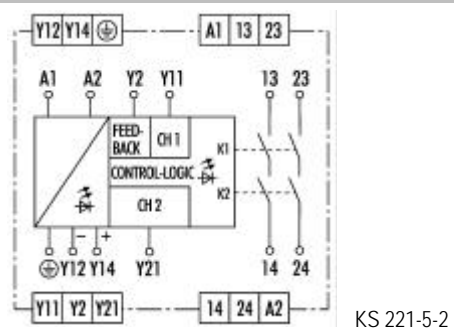

KS 221-5-2

Assembly

- 1 Hang the relay on the top-hat rail.
- 2 Apply light pressure in the direction of the arrow to snap the relay onto the top-hat rail.

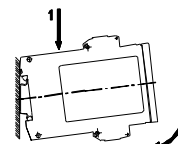

Disassembly

- 3 Push the relay down in direction of the arrow.
- 4 While pushing down, pull the relay in the direction of the arrow out of the detent and off the top-hat rail.

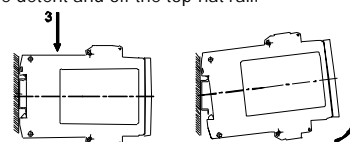



Two-Hand Relay

SNZ 5052K

Application Example

Two-hand application acc. to type III C for safety category 4 acc. to EN 574-1 and/or EN 954-1

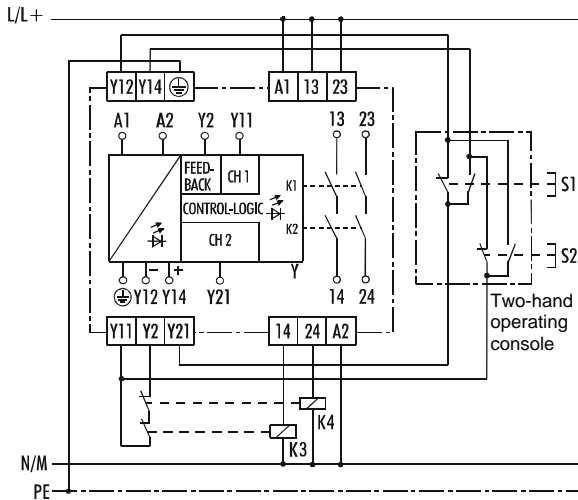

The device monitors the position of the two-hand switches S1 and S2. The SNZ 5052K is in a ready state, if none of the switches are activated and the contactor feedback circuit (Y1-Y2) is closed. Upon simultaneous operation of switches S1 and S2, the device will be enabled through 13/14 and 23/24. If activation of both switches does not occur within the synchronous time, they will not be enabled. An automatic restart is possible.

Application Example

Two-channel sliding protective gate application (with bridge-fault detection) with automatic start for safety category 4 acc. to EN 954-1

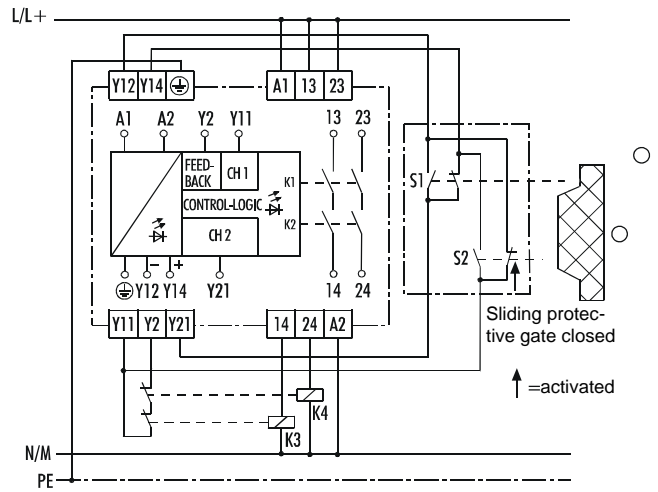

The device monitors the position of the sliding protective gate and/or the S1 and S2 switches. When the sliding protective gate is open and the contactor feedback circuit (Y11-Y2) is closed, the SNZ 5052K is ready for activation. When the gate closes and the S1 and S2 switches are operated simultaneously, the automatic start will enable the relay through 13/14 and 23/24. Monitoring of the simultaneous operation of S1 and S2 increases the safety of the application.

Dimension Diagram

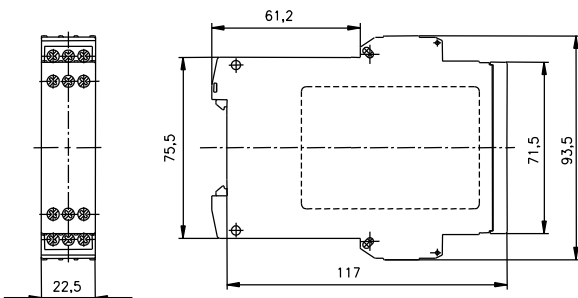



Two-Hand Relay

SNZ 5052K

Technical Specifications

General data

Weight	0.27 kg
Ambient temperature, operating range	-25 to +55 °C
Climate application class	H V G acc. to DIN 40040: 04.87
Air and creepage paths	acc. to DIN VDE 0110 part 1: 04.97
Over-voltage category	IV
Rated surge voltage	6 kV
Contamination level	2
Rated voltage	300 V
Test voltage	2 kV
Safe isolation acc. to DIN EN 50 178 between	Supply circuit – control circuit (only for AC devices) Supply circuit – output circuits Control circuit – output circuits Output circuits

Supply circuit

Rated voltage U_N	24 V DC
Residual ripple of the DC supply	24 V AC, 115 - 120 V AC, 230 V AC
Rated consumption	2.4 V_{SS}
DC supply	1.3 W
AC supply	2.5 W / 3.2 VA
Operating range	0.85 to 1.1 U_N
Fusing	PTC resistor
DC supply	Short-circuit-proof transformer
AC supply	

Control circuits

Output Y12 / Y14	
Rated voltage / non-load voltage (AC)	22 V- / ≤ 40 V-
Inputs Y11 and Y21	
Rated current / peak current	45 mA / 200 mA
Times	
t_R , disengagement time (response time acc. to EN 574-1)	< 50 ms
t_S , synchronous time	≤ 500 ms
t_A , response time	40 ms
t_B , standby time	max. 400 ms
t_W , recovery time	max. 400 ms

Output circuits

Enable contacts	2 N/O, undelayed
Contact type	Single contact, positively driven
Contact material	Ag Sn O ₂ + 2 μ m Au
Max. switching current I_n / contact fusing	6 A / 6.3 A fast-acting, or 4 A slow-acting
Rated switching voltage U_n	230 V- / 230 V-
Application category acc. to	AC-15: $U_e = 230$ V, $I_e = 4$ A (360 switching cycles / h)
DIN VDE 0660 part 200: 07.92	DC-13: $U_e = 24$ V, $I_e = 4$ A (360 switching cycles / h)

LED indicators (green)

SUPPLY	Supply voltage ON
K1, K2	Relays K1 and K2 are switched, enable activated

Standards

DIN EN 574:1997	DIN EN 60204-1:1998
DIN EN 60947-1:1999	DIN EN 50178:1998
DIN EN 60529:2000	DIN EN 954-1:1997
DIN EN 60439-1:2000	DIN VDE 0110-1:1997
	DIN EN 60947-5-1:2000

Subject to change

SCHLEICHER GmbH & Co.
RELAIS-WERKE KG
Pichelswerderstraße 3-5
D-13597 Berlin

Tel: 030 33005 – 0 Fax: 030 33005 - 378
Hotline 030 33005 - 304
www.schleicher-de.com
info@schleicher-de.com