



Light Barrier Evaluation and Test Device

Basic unit acc. to EN 60204 - 1 and EN 954 - 1
For type 2 acc. to EN 61496
Cyclic Test, OVERRIDE function
Cross monitoring, RESET key monitoring
2 input channels, single or dual channel with contacts
or/and semiconductors
2 N.O. safety contacts, 1 N.C. control contact

| | | | |
|--------------|------------|-------------------|---|
| SNL 4062 K | EN 60204-1 | For Stop Category | 0 |
| SNL 4062 K-A | EN 954-1 | Safety Category | 3 |
| | EN 61496-1 | BWS Typ | 2 |

SNL 4062 K SNL 4062 K-A



For Example

- ▶ Monitoring one-way safety light barriers mit Testeingang
- ▶ Emergency-Stop and protective gate applications
- ▶ Protection of persons, material, and machinery in a transfer area, access protection

Function

The light barrier evaluation and test device SNL 4062 K operates as interface between optoelectronic protective equipment (in compliance with the EN 61496-1/-2 type 2 norm), and machine controllers. The device is used to protect dangerous areas around forced operated machinery. The device has the following embedded features: START inhibition, RESTART inhibition, OVERRIDE, selftest, cyclic test, time monitoring, feedback of the external contacts and forced guided safety contacts at the output.

After the supply voltage is applied to terminals A1/A2 and the selftest has been successfully performed, the device is ready to operate and the LED OUTPUT is lighted yellow. If the selftest is unsuccessful the program is aborted and a new START is necessary. Therefore the device activation depends from: the results of the selftest, the selected operation mode, and the status of the external connected circuit (see our "Function Flow Chart" on the next page).

The presence of the light barrier signal at inputs Y12, Y22 and at outputs Y41, Y42 is checked within 150 ms (t_4) and is displayed by the LED INPUT. In case of presence of signal at the light barrier input, the safety output contacts of the SNL 4062 K stay open until the RESET key is closed first, and then released (RESTART inhibit circuit active). The following contacts at the output are available: 2 N.O. safety contacts and 1 N.C. safe control contact. The LED OUTPUT displays the status at the outputs in different colors:

- YELLOW = device is ready to operate
- GREEN = the N.O. safety outputs are closed
- RED = the N.O. safety outputs are opened

The safety output contacts open immediately if one of the following four cases occur:

1. No signal at the light barrier inputs in case they have been previously enabled.
2. No control signal at the OVERRIDE input during the OVERRIDE operation if no signal is also present at the light barrier inputs.
3. A fault has been detected during the cyclic selftest.
4. If during the OVERRIDE operation a signal will appear at both light barrier inputs.

The SNL 4062 K will be ready to operate after all protective equipment has been triggered. All internal tests and start procedures within the device will be performed again. The device will restart operating according to the standard procedure only if during the START test no faults have been detected (LED OUTPUT is yellow).

Operation modes

Available features: Test pulse direction (pos./neg. pulse), RESTART inhibit circuit (ON/OFF) and OVERRIDE (static/dynamic). Operation without RESTART inhibit circuit allows automatic or manual START depending from the external wiring. The preselection of the operation mode is done on the rear part of the enclosure by means of DIP switches (see fig. 1). These switches are not accessible once the item is mounted on DIN-rail.

OVERRIDE

The device has an OVERRIDE input X1 which can be activated if the light barrier (SL) has to be bypassed due to necessary operational process (LED OVR is yellow). The activation occurs through the enabling current paths of a separate unit, as a result the relays K1 and K2 do not drop during the override phase if the light barrier is interrupted.

SNL 4062 K-A

Their functions correspond to the ones of the SNL 4062 K. The items with reference containing the letter -A have 4 removable terminals. This feature allows a quick installing/removing operation. The terminal locations are coded and non-interchangeable.

Function Diagram

FD 0221-26-1 W1

SNL 4062 K, SNL 4062 K-A Operation Mode w/o OVERRIDE with RESTART Inhibit Circuit

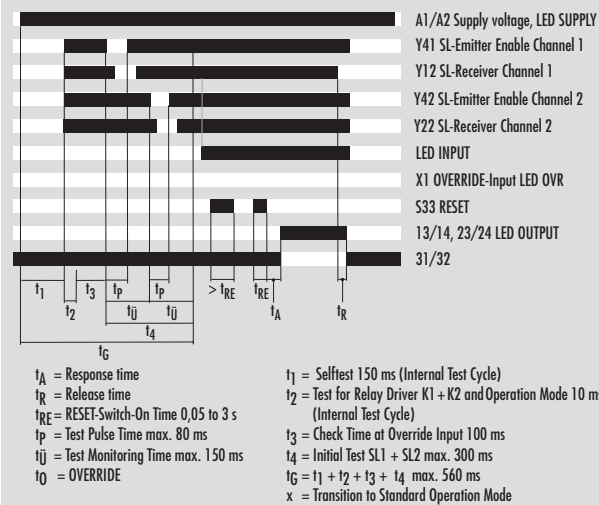

FD 0221-26-2 W1

Operation Mode with Override Function

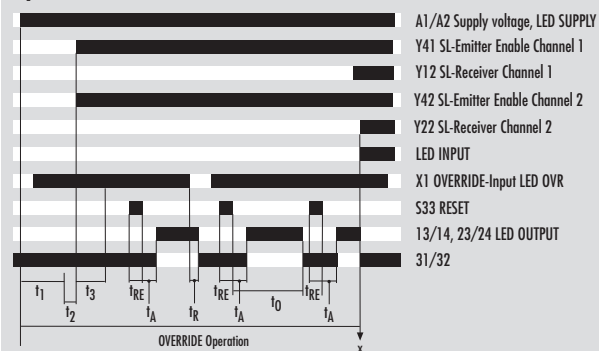



SNL 4062 K

Notes

- ▶ No external power supply can be applied to terminal S34 of the RESET key circuit. The RESET key can only be supplied through terminal S33 (internal supply).
- ▶ In case of applications where several light barriers are connected in serial, beware that the maximum total response time for the cyclic test must be ≤ 150 ms.
- ▶ The safety category according to EN 954-1 also depends from the external circuit, the choice of the control station and its location on the machine.
- ▶ The OVERRIDE function impairs the safety-relevant operation of the light barrier evaluation unit. With regard to this, please note the information provided by your Professional Association.
- ▶ In case of Emergency-Stop applications the RESTART inhibit circuit is mandatory.
- ▶ Insulation on external wiring should not be cut back more than 8 mm.
- ▶ To multiply the enabling current paths, the expansion units or external contactive elements with positively driven contacts can be used.
- ▶ External fuse protection for the relay and the contacts should not exceed 6 A type gG.
- ▶ The item is equipped with an overload protection against short circuits.

Order Example

| | |
|---------------------|---------------|
| SNL 4062 K | 24 V DC |
| SNL 4062 K-A | 24 V DC |
| Type | Rated Voltage |

Connection Diagram

KS 0221-26 W1

SNL 4062 K

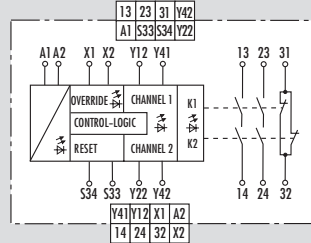

SNL 4062 K-A

REMOVABLE TERMINALS

| | | | |
|-----|-----|-----|-----|
| 3.1 | 3.2 | 3.3 | 3.4 |
| 13 | 23 | 31 | Y42 |
| 1.1 | 1.2 | 1.3 | 1.4 |
| A1 | S33 | S34 | Y22 |
| | | | |
| Y41 | Y12 | X1 | A2 |
| 2.1 | 2.2 | 2.3 | 2.4 |
| 14 | 24 | 32 | X2 |
| 4.1 | 4.2 | 4.3 | 4.4 |

The connections designations on the removable terminals correspond to the ones marked on the device

Fig. 1

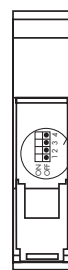

- ON OFF
1 2 3 4
- Switch positions are factory preset
- Switch 1
OFF = Override operation mode by means of a dynamic input signal
ON = Override operation mode by means of a static input signal
- Switch 2
OFF = Operation with RESTART inhibit circuit
ON = Operation without RESTART inhibit circuit
- Switch 3
OFF = Input test by means of positive test pulse
ON = Input test by means of negative test pulse
- Switch 4 = no function

Dimension Diagram

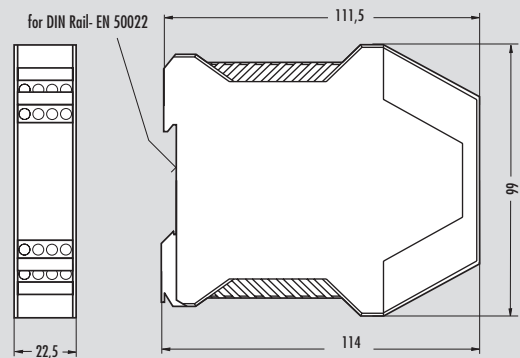

K 2-1

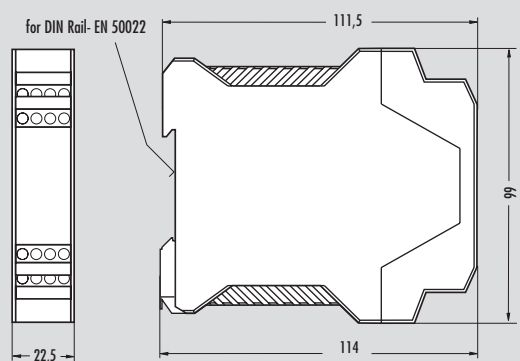

K 2-2



SNL 4062 K

Application Example

Light Barriers with Test /Activation Input and Light Barrier Evaluation and Test Device

1

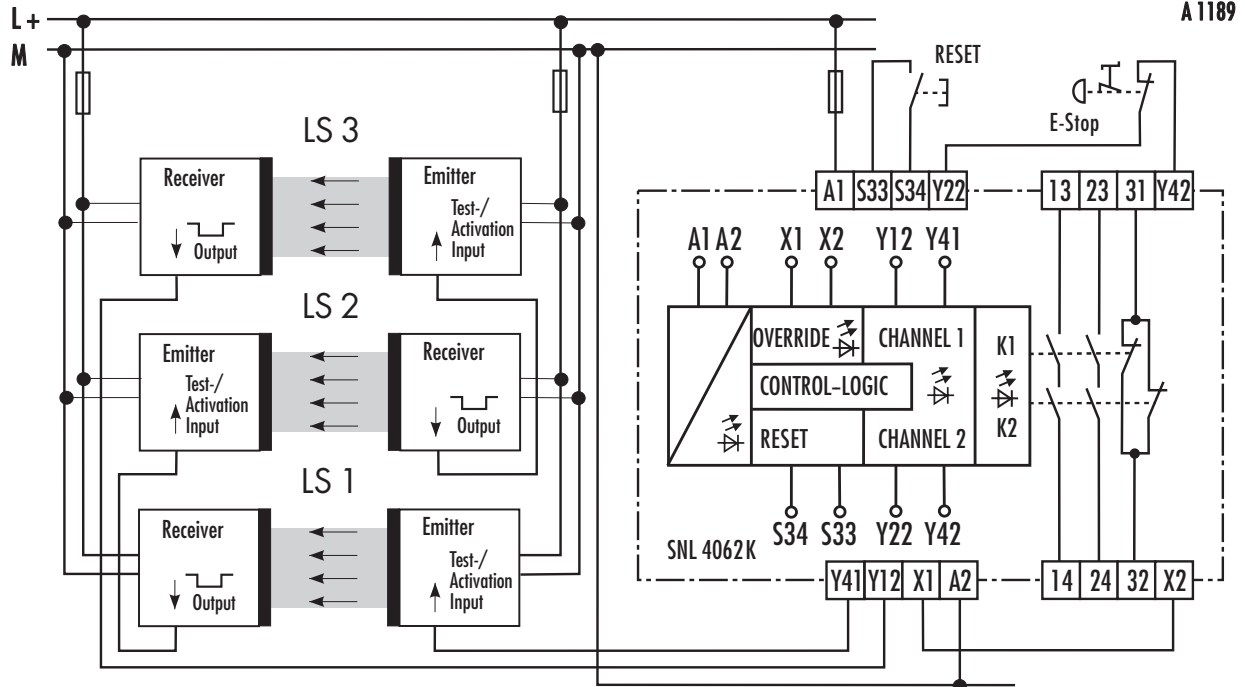

After the supply voltage has been applied, there are no obstacles between the light beams and the Emergency-Stop circuit is closed a special **selftest** is performed.

If the selftest has been successful, depending from the preselected operation mode, the safety output contacts are closed. Subsequently a **cyclic test** is performed. This cyclic test simulated the response or the functionality of: the sensors in channel A, the check for example of the Emergency-Stop circuit in channel B, the test and monitoring device.

All cyclic tests are performed during the waiting time before the enable signal appears and in a period of time of 6 s approx. if the device has been already enabled.

For a light barrier test the maximum test pulse time is of 80 ms and the max. test monitoring time is of 150 ms. The test pulse can be interrupted before its max. test pulse time has elapsed, immediately after the first pulse signal has been detected. The test will be positively ended when a second pulse signal is detected. The LED INPUT and OUTPUT flash shortly during these tests.

If the first or the second pulse signal are not detected within the maximum test monitoring time the device detects the failure.

The SNL 4062K checks cyclically following functions:

- light barrier running time error
- lost of the sensor detection capacity
- exceeding of the fixed reaction times
- short circuits
- cross monitoring
- fluctuation of the power supply

In case of negative result of the cyclic test (for example the output switching element of the receiver OSSD is defective) the safety outputs of the SNL 4062K will immediately open after 20 ms. The device is still ready to operate as the main power supply is still applied and the selftest first and then all the internal and START tests will be performed newly. The interlocking state of the SNL 4062 K will be removed according to its respective operation mode only after the reason for the failure has been eliminated and the START test has been successfully performed.

The external OVERRIDE function can be disabled jumpering terminals X1 - X2.

With reference to the application example, following functions have been selected at the operation mode DIP switches:

- DIP switch 1 = OFF or ON position (OVERRIDE is disabled jumpering terminals X1 - X2 for both positions)
- DIP switch 2 = OFF position RESTART inhibit circuit
- DIP switch 3 = OFF position test pulse direction



TECHNICAL DATA

SNL 4062 K

SNL 4062 K-A

FUNCTION According to EN 50100-1
Function Display
Function Diagram

Light Barrier Evaluation and Test Device
3 LED green, 1 LED yellow (MUTING)
FD 0221-26-1 and -2 W1

POWER SUPPLY DATA

Rated Voltage U_N V DC
Rated Consumption at U_N (DC) W
Residual Ripple V_{ss}
Operating Voltage Range

24
1,8
2,4
0,85 to 1,1 x U_N

CONTROL CIRCUIT

No Isolation between A1, A2 and X1, X2,
Y12, Y22, Y41, Y42, S33 and S34
Fuse: PTC Resistance; Response-/Recovery Time s
Control Input S34 V DC
Rated Current Input S34 mA
Min./Max Switch-On Time RESET t_{RE} ms
Self Test t_1 ms
Test for Relays Driver t_2 ms

No
PTC-Resistance; 2/3
 ≤ 24
10
50/3000
150
10

INPUT CIRCUIT

No. of Input
High/Low Peak Input Y12, Y22 V DC
Rated Current Input Y12, Y22 mA
Test Signal Y41, Y42 Neg. Pulse V DC
Rated Current Test Signal Y41, Y42 mA
Initial Test t_d ms
Max. Total Check Time t_1 to t_d ms
Response Time t_A (with restart inhibit) ms
Release Time t_R ms
Max. Check Pulse Time t_P ms
Max. Test Monitoring Time t_U ms
Test Cyclic Time s

2
15 to 26,4/ ≤ 8
12,5
24
 $< 12,5$
300
560
50
20
80
150
6

OVERRIDE CIRCUIT

No. of Input
High/Low Peak Input X1 V DC
Rated Current Input X1 mA
Static Control ; Min. Switch-On Time, Static ms
Input Frequency Range, Dynamic Hz
Pulse Duty Factor
Check Time at OVERRIDE Input t_3 ms

1
15 to 26,4/ ≤ 8
10
66
18 to 23
1:1
100

OUTPUT CIRCUIT

Contact Equipment:

Contact Type
Contact Material
Switching Voltage U_n V AC/DC
Maximum Continuous Current per Contact A
Total of All Contact Currents A
Application Category According to IEC 947-5-1

Short-Circuit Protection, Max. Fuse Element Class gG A
Permissible Switching Frequency Switching Cycles/h
Mechanical Lifetime Switching Cycles

2 N.O. Safety Contact
1 N.C. Control Contact
Forced Contact
Ag-Alloy; Gold-Plated
230/230
12
AC-15 U_e 230 V AC, I_e 6 A to 3600 Sch/h
DC-13 U_e 24 V DC, I_e 6 A to 360 Sch/h
DC-13 U_e 24 V DC, I_e 3 A to 3600 Sch/h
6
3600
30 x 10⁶

GENERAL DATA

Creepage and Clearance Distances Between Circuits
According to DIN VDE 0110-1:04.97:Rated Withstand Voltage kV
Over-Voltage Category III
Contamination Level 3 Outside, 2 Inside
Design Voltage V
Test Voltage U_{eff} 50 Hz acc. to DIN VDE 0110-1, Table A.1 kV
Protection Class Housing/Terminals acc. to DIN VDE 0470 Sec. 1:11.92
Radiated Noise EN 50081-1:03.93, -2:03.94
Noise Immunity EN 50082-2:1995

Ambient Temperature, Working Range °C
Dimension Diagram: SNL 4062 K/SNL 4062 K-A
Connection Diagram
Weight kg
Approvals

4
III
3 Outside, 2 Inside
300
2,21
IP 40/IP 20
EN 50081-1:03.93, -2:03.94
EN 50082-2:1995

- 25 to + 55
K 2-1/K 2-2
KS 0221-26 W1
0,21
BG, CSA, UL (Pending)

GENERAL TECHNICAL SPECIFICATIONS

Page i/11