

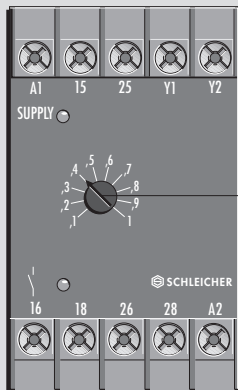

## Contact Protection Relay

**Supply Voltage and Control Circuit are Electrically Isolated**  
**On- and Off-Delay Time**  
**Number of Contacts: 2 Changeover or 1 N.O., 1 N.C.**

### SST 12



ON- and OFF-Delay Time

### For Example

- ▶ Protect sensitive switching contacts, e.g. measuring instruments, manometers, pressure monitors
- ▶ Avoiding contact bouncing
- ▶ As time relay for short times (ON- and OFF-delay times)
- ▶ As level monitor in connection with float switches

### Function

#### SST 12

The contact protection relays are constantly connected to an operating supply voltage. The supply voltage is electrically isolated from the control circuit by means of a built-in transformer.

If the control circuit is closed (e.g. by exceeding the limit value in a contact manometer), the relay switches into the operating position after the selected ON-delay time has elapsed. By opening of the control contact the relay switches back into the off position after the OFF-delay time has elapsed.

The ON-delay time and the OFF-delay time are identical. The open control contact is supplied with a voltage  $\leq 11$  V DC. A current  $\leq 2$  mA DC flows via the closed control contact. In this way the control contact is not overloaded.

Number of contacts is: 2 changeover

#### KST 12

It functions as the SST 12, however the number of contacts : 1 NO, 1 NC.

### KST 12

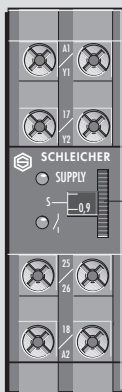

ON- and OFF-Delay Time

### Notes

- ▶ In a contact manometer a control contact indicates the exceeding of the selected limit value. The contact should not impede the movement of the pointer. In order to fulfill this requisite very small control contacts are used. They support a maximum load of 25 mW. With a higher load the contacts would be destroyed.

- ▶ A correct function is guaranteed if the total ohmic value of lines and contact resistances is not greater than 500  $\Omega$ .

### Adjustment Range

ON- and OFF-Delay Time: 0,05 to 1 s

### Connection Diagram

SST 12 KS 0138/1

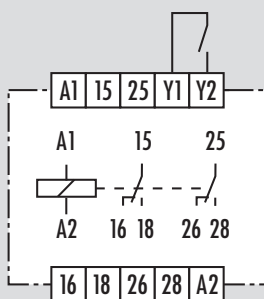

### Connection Diagram

KST 12 KS 0287/1

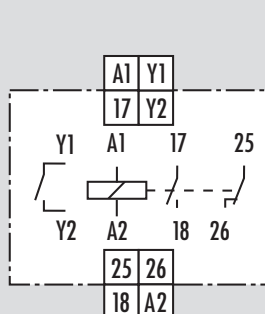



## SST 12 KST 12

### Application Example

A 1067

#### Protection of a Manometer Contact

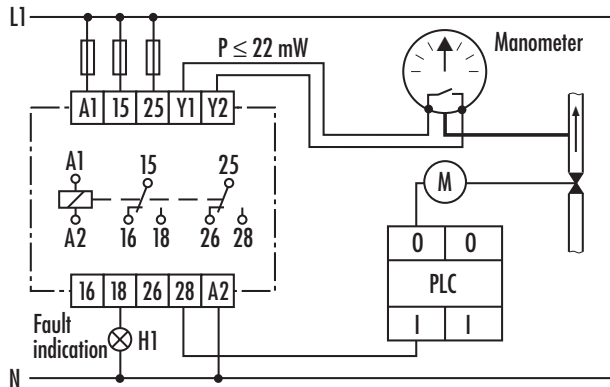

The manometer monitors the pressure in the pipeline. If the pressure exceeds the selected limit value, the contact protection relay switches in the operating position. A signal is transmitted to the PLC. The valve is closed. The lamp H1 indicates that the limit value has been exceeded.

### Order Example

**SST 12** 220-240 V AC  
 |  
 Type Rated voltage

### Function Diagram

FD 0082 W1

#### SST 12, KST 12

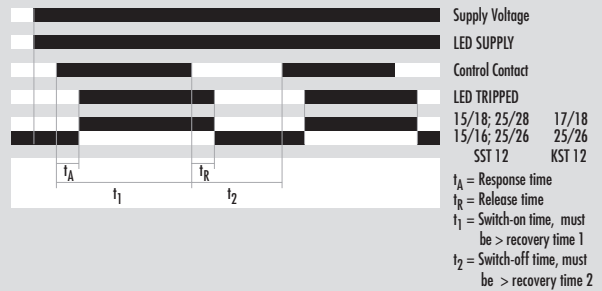

### Dimension Diagram

S 3-2

#### SST 12

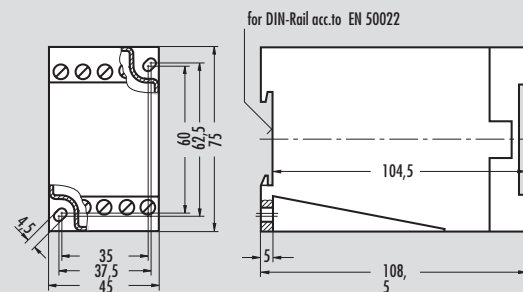

### Accessory

Cover Z 29

#### SST 12

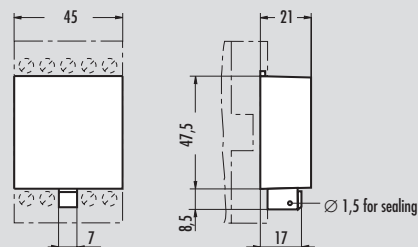

### Accessory

Adaptor Z 15

#### KST 12

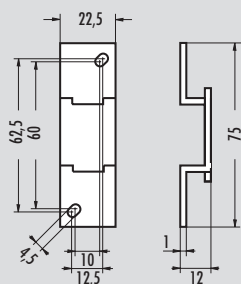

### Dimension Diagram

K 1-12

#### KST 12

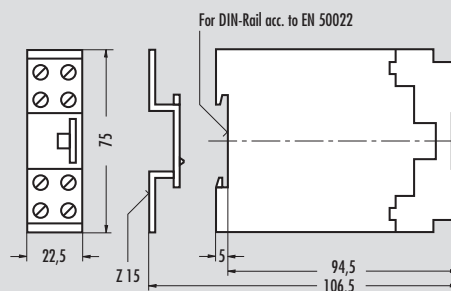



## TECHNICAL DATA

**FUNCTION** According to DIN VDE 0435 Sec. 2021:09.86  
Function Display  
Function Diagram

### POWER SUPPLY

Rated Voltage $U_N$	V AC
Rated Consumption at 50 Hz and $U_N$ (AC)	VA
Rated Consumption at 50 Hz and $U_N$ (AC)	W
Rated Frequency	Hz
Operating Voltage Range	

### Time Circuit

Time Setting/No. of Time Ranges	
Available Time Ranges	s
Recovery Time 1/2	ms
Minimum Switch ON Time	ms
Release Value	% $U_N$
Permissible Parallel Load	
Internal One-Way Rectifier	
Average Value of the Error	%
Electrical Isolation	
Voltage at Open Control Input Y1	V DC
Current Through Closed Control Contact Y1	mA
Maximum Resistance of the Control Circuit	$\Omega$

### OUTPUT CIRCUIT

Contact Type	
Contact Material	
Switching Voltage $U_n$	V AC/DC
Maximum Rated Current $I_n$ per Contact	A
Application Category acc. to EN 60947-5-1:1991	
Short-Circuit Protection Max. Fuse Class gG	A
Permissible Switching Frequency	Switching Cycle/h
Mechanical Lifetime	Switching Cycles
Response Time $t_A$	ms
Recovery Time $t_R$	ms

### GENERAL DATA

Creepage and Clearance Distances Between Circuits	
According to DIN VDE 0110-1:04.97: Rated Withstand Voltage	kV
Over Voltage Category	
Contamination Level	
Design Voltage	V
Test Voltage $U_{eff}$ 50 Hz acc. to DIN VDE 0110-1, Table A.1	kV
Protection Class Housing/Terminals acc. to DIN VDE 0470 Sec. 1:11.92	
Radiated Noise	
Noise Immunity	

Ambient Temperature, Working Range	$^{\circ}\text{C}$
Dimension Diagram	
Connection Diagram	
Weight	kg
Accessory	

### GENERAL TECHNICAL SPECIFICATIONS

## SST 12

Contact Protection Relay  
1 LED green 1 LED red  
FD 0082 W1

24	42	110 - 127	220 - 240
3,2	3,2	2,7	3,2
2,8	2,8	2,4	2,8
50 to 60			
0,8 to 1,1 x $U_N$			

analog/1
0,05 to 1
200/200
-
-
no
no
$\pm 20$
yes
$\leq 11$
$\leq 2$
500

2 Changeover
Ag - Alloy; Gold - Plated
230/230
$\leq 5$
AC-15: $U_e$ 230 V AC, $I_e$ 2 A
DC-13: $U_e$ 24 V DC, $I_e$ 2 A
6
6000
$30 \times 10^6$
10
10

4
III
3 Outside, 2 Inside
250
2,2
IP 30/IP 20
EN 50081-1:03.93, -2:03.94
EN 50082-2:1995

-20 to+ 60
S 3-2
KS 0138/1
0,4
Cover Z 29

Page i.11

## KST 12

Contact Protection Relay  
1 LED green, 1 LED red  
FD 0082 W1

24	42	110	127	220 - 240
1,5	1,5	1,5	1,5	1,5
1,6	1,6	1,6	1,6	1,6
50 to 60				
0,8 to 1,1 x $U_N$				

analog/1
0,05 to 1
200/200
-
-
no
no
$\pm 20$
yes
$\leq 11$
$\leq 2$
500

1 N. Closed, 1 N. Open
Ag - Alloy; Gold - Plated
230/230
$\leq 5$
AC-15: $U_e$ 230 V AC, $I_e$ 2 A
DC-13: $U_e$ 24 V DC, $I_e$ 2 A
6
3600
$20 \times 10^6$
10
10

4
III
3 Outside, 2 Inside
250
2,2
IP 30/IP 20
EN 50081-1:03.93, -2:03.94
EN 50082-2:1995

-20 to+ 60
K 1-12
KS 0287/1
0,17
Adaptor Z 15

Page i.11