

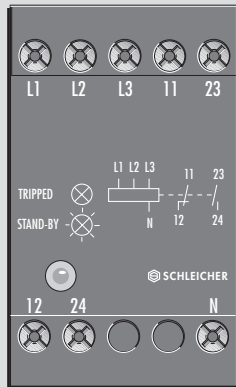

Neutral Conductor and Phase Monitor

For Three Phase Current in the Supply Network
Monitoring the Neutral Conductor
Monitoring the Phases L1, L2 and L3
Closed Circuit Principle
Indication even if the Loads are Isolated

SNW 1002



ENW 1001

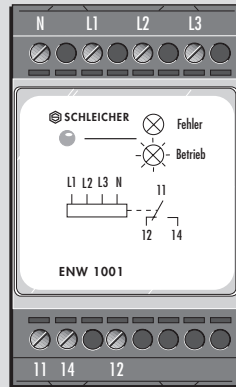

For Example

- ▶ Monitoring the voltage supply of worksite containers
- ▶ Monitoring of:
 - Low voltage distributors
 - Worksite electrical systems
 - Fuses
 - Conductors

Function

The SNW 1002 monitors the neutral conductors and the three phases. If the neutral conductor and all three conductors for the phases L1, L2 and L3 are connected, the output relay switches into its operating condition. The contact 11/12 opens, and the contact 23/24 closes (closed-circuit principle), the green LED lights up. If a terminal, or the neutral conductor, or one of the three phases is missing when the conductors are connected to a load, the output relay remains in its de-energized position. The contact 11/12 is closed, the contact 23/24 is opened, the LED goes out. The same also applies when the neutral conductor is exchanged with one of the three phases. If one conductor becomes loose during trouble-free operation, the relay drops back into its de-energized position and the LED goes out.

Connection Diagram

KS 0333/1

SNW 1002

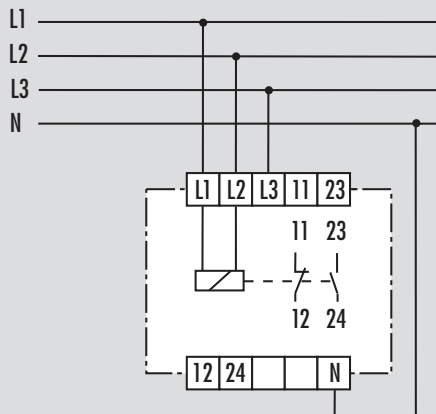

ENW 1001

The function of the ENW 1001 corresponds to the function of the SNW 1002. However, the output relay has only one changeover contact.

Notes

- ▶ The SNW 1002 is suited for mounting in cabinets, while the ENW 1001 is designed for installation in low-voltage distributors.
- ▶ Voltage feedbacks from connected loads up to 85 % of the voltage are detected.
- ▶ A transformer is connected at the terminals L1, L2, L3 and N of the SNW/ENW. Before installation and voltage tests of the system, the neutral conductor monitor should be isolated from the network.

Order Example

SNW 1002 380 to 415 V 3 AC
 Type Rated Voltage

Connection Diagram

KS 0331/2

ENW 1001

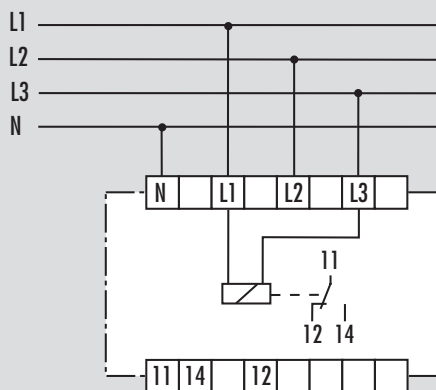

5

SNW 1002, ENW 1001

Application Example

A 1073

Neutral Conductor Monitor

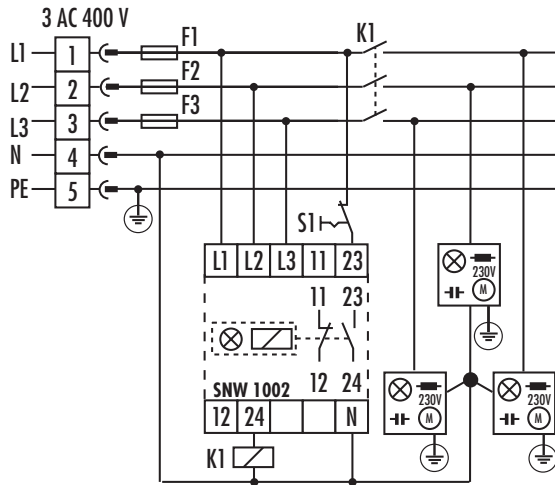

The example shows a standard application of the neutral conductor monitors SNW 1002 and ENW 1001. The function of the relays is described on the preceding page.

Function Diagram

SNW 1002

FD 221-2 W1

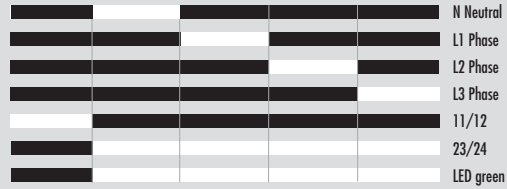

Function Diagram

ENW 1001

FD 221-1 W1

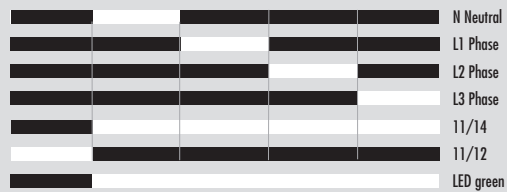

Application Example

A 1074

Monitoring of Worksite Containers

3 AC 400 V

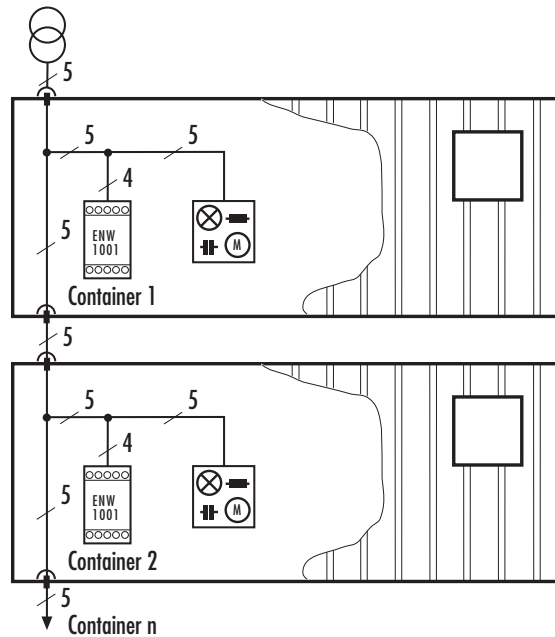

The voltage supply of flexible containers at worksites is obtained from the three-phase network through connecting lines that run from container to container.

Voltage failures can easily occur as a result of different connection systems (plugs and couplings) or damage to conductors. This can damage the loads in the container or can jeopardize the operating personnel (e.g. at machines in the workshop containers).

The neutral conductor monitors, and phase monitors SNW 1002/ENW 1001 are used to monitor the connecting lines. If the strands of these lines are damaged or exchanged, the relays report this fault and turn the system off.

Dimension Diagram

S7-1

SNW 1002

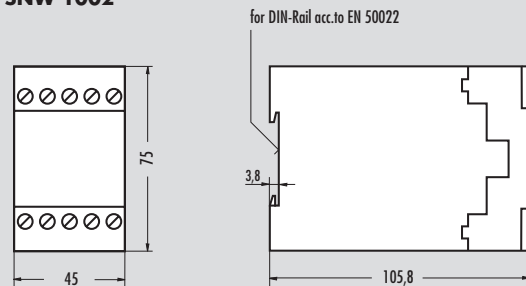

Dimension Diagram

EMG 45-LG

ENW 1001

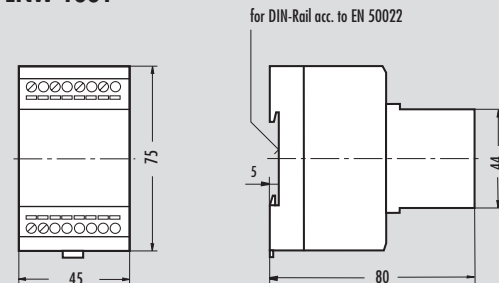



TECHNICAL DATA

FUNCTION According to DIN VDE 0435 Sec.I 303:09.84

Function Display
Function Diagram

POWER SUPPLY

Rated Voltage U_N 3 AC V

Rated Consumption at 50 Hz and U_N (L1; L3 AC) VA
 Rated Consumption at 50 Hz and U_N (L1; L3 AC) W
 Input Current at 50 Hz and U_N (L2 AC) mA
 Rated Frequency Hz
 Operating Voltage Range
 Unbalance Of The Network Acc. to DIN VDE 0530 Sec, 1:07.91 %

OUTPUT CIRCUIT

Contact Equipment
 Contact Material V AC/DC
 Switching Voltage U_n A
 Maximum Rated Current I_n per Contact
 Application Category According to EN 60947-5-1:1991
 Short-Circuit Protection, Max. Fuse Element Class gG A
 Permissible Switching Frequency Switching Cycle/h
 Mechanical Lifetime Switching Cycles
 Response time in case of neutral line failure ms
 Release time in case of restoration of the neutral line ms
 Response time in case of failure of one or more phases ms
 Release time in case of restoration of one or more phases ms
 Recovery Time ms

GENERAL DATA

Creepage and Clearance Distances Between Circuits
 According to DIN VDE 0110-1:04.97: Rated Withstand Voltage kV
 Over-Voltage Category
 Contamination Level
 Design Voltage V
 Test Voltage U_{eff} 50 Hz acc. to DIN VDE 0110-1, Table A.1 kV
 Protection Class Housing/Terminals acc. to DIN VDE 0470 Sec. 1:11.92
 Radiated Noise
 Noise Immunity

Ambient Temperature, Working Range °C
 Dimension Diagram
 Connection Diagram
 Weight kg

GENERAL TECHNICAL SPECIFICATIONS

SNW 1002

Neutral Conductor Monitor
 Closed Circuit Principle
 1 LED green
 FD 221-2 W1

**380
- 415**
 3,2
 2,8
 < 0,5
 50 to 60
 0,8 to 1,1 x U_N
 max. 5

1 Open, 1 Closed
 Ag Cd O
 230/230
 ≤ 5
 AC-15: U_e 230 V AC, I_e 3 A
 DC-13: U_e 24 V DC, I_e 2 A
 6
 3600
 30 x 10⁶

4
 III
 3 Outside, 2 Inside
 400
 2,2
 IP 30/IP 20
 EN 50081-1:03.93, -2:03.94
 EN 50082-2:1995

- 20 to + 60
 S 7-1
 KS 0333/1
 0,27

Page i.11

ENW 1001

Neutral Conductor Monitor
 Closed Circuit Principle
 1 LED green
 FD 221-1 W1

**380
- 415**
 3,0
 2,5
 < 0,5
 50 to 60
 0,8 to 1,1 x U_N
 max. 5

1 Changeover
 Ag - Alloy; Gold-Plated
 230/230
 ≤ 5
 AC-15: U_e 230 V AC, I_e 3 A
 DC-13: U_e 24 V DC, I_e 2 A
 6
 3600
 30 x 10⁶
 < 400
 < 700
 < 400
 < 700

4
 III
 3 Outside, 2 Inside
 400
 2,2
 IP 30/IP 20
 EN 50081-1:03.93, -2:03.94
 EN 50082-2:1995

- 20 to + 60
 EMG 45-LG
 KS 0331/1
 0,19

Page i.11